

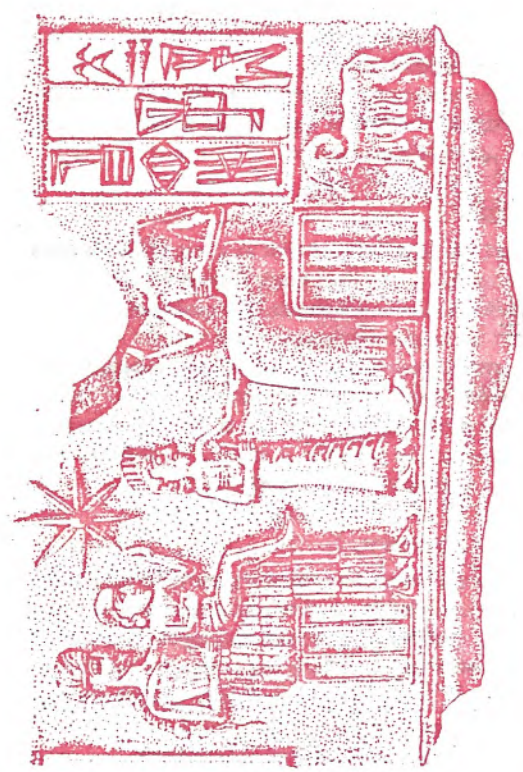

GIORGIO BUCCELLATI

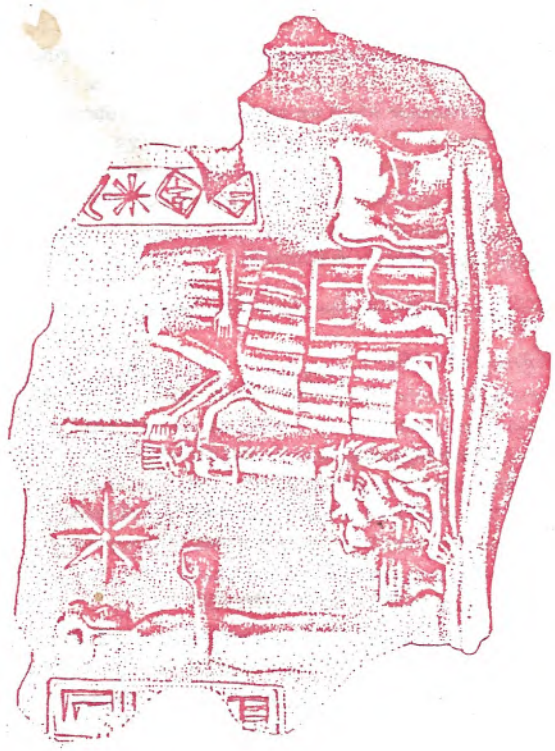

Principles and Presuppositions2

System Configuration: The Data

1 Structure of the data: general parameters.....3
2 Structure of the data: minimal constituents4
3 Constituents: definitions5
4 Constituents: descriptions.....6
5 Constituent label: ranks7
6 Directory of computer files: Excavation Units8
7 Codes for elements and components9

System Configuration: The Record

8 Journal: procedures10
9 Structure of journal: basic concepts and diary11
10 Structure of journal: logs and lists12
11 Sample journal entry: diary13
12 Sample journal entry: logs14
13 Sample journal entry: lists15

Rosters and Lexica

14 Main roster: identification of slots16
15 Combined lexicon of variants17
16 Lexicon of pottery shapes (MKB)18
17 Lexicon of depositional verbs19
18 Lexicon of depositional nouns20
19 Photo roster and lexicon21

Forms

F1 F log (features)22
F2 K log (loci)
F3 A log (aggregates)
F4 I log (items)23
F5 Q log (lots)
F6 R log (relays)24
F7 V log (views)
F8 Photo log25
F9 S log (strata)
F10 Specific label log
F11 File log26
F12 Film log

Standards

S1 Emplacement record27
S2 Soil record28

Utilities

U1 Symbols and abbreviations29
U2 Staff; Calendar30

Appendices

1 Map of region31
2 Site plan: The Outer City32
3 Site plan: The High Mound33
4 AK: floor plan34
5 Chronologies35
6 The inscribed seals36

1. *Archaeology as archaeology*

Stratigraphic analysis as primary task of archaeology, totally unique to this field.

Analysis of broken traditions as secondary task, partly unique.

2. *Archaeological universals*

If there are any archaeological "laws," they pertain only to (a) disposition of elements in the ground, and (b) assumptions about depositional processes.

Other "laws" are, at best, behavioral, not archaeological, in nature.

3. *Grammar of space*

The disentanglement of elements in the ground, and their accurate documentation, are the primary duty of the archaeologist.

A coherent and all-inclusive descriptive system is both a theoretical and a practical requirement for success in the archaeological endeavor. Conceptually, it may be likened to the grammar of a language, whose explanatory power depends on its ability to account for the totality of the system with the smallest and most integrated network of rules.

Comparison to the architectural notion of "grammar of space."

4. *Inferences about deposition*

Deposition is not observable, therefore it cannot be documented; it can only be inferred on the basis of observed space relationships.

Depositional arguments are about temporal and causal phenomena which are presumed behind a given spatial configuration.

Concept of deposition is conceptually preferable to the concept of site formation.

5. *Operational difficulties of stratigraphic analysis*

The major difficulty is the one generally recognized about the fact that the evidence is destroyed at the very moment that it is established. Considering the seriousness of this presupposition, one wonders why so little attention is paid to the problem. Most efforts have been on the level of implementation rather than theory.

Other difficulties not sufficiently appreciated include the following.

(1) The surfeit of data (stratigraphic, not typological) is such that, even when they are recorded, they can be quickly lost as if in a quagmire. (2) Discrepancy between intended precision and actual accuracy. (3) Discrepancy between accuracy in recording and retention of such accuracy during analysis.

Since these problems are generally ignored, the archaeological record as it is generally presented can hardly be called objective by established scientific standards.

6. *Stratigraphic understanding after excavations*

Two additional problems may be attributed to underlying attitudes brought to the excavation process. The first is the implicit assumption that the stratigraphic moment can be clarified either through further study of the evidence assembled during the excavation, or through further excavation. Both are fallacious. Further study only clarifies by obfuscating - i.e. it obfuscates the objectivity of the record in order to clarify the archaeologist's perception of the resulting synthesis. Further excavation amasses more data which are often extraneous to the stratigraphic reality disentangled earlier, because they are not physically contiguous with that reality.

Both further study and further excavation clarify only the typological, not the stratigraphic reality.

7. *Reductionist documentary approach*

The standard *modus operandi* takes for granted a progressive reduction in the documentary effort, which may be phrased as follows: (1) we select a portion of the evidence which we presume to be pertinent to a proposed research strategy; (2) of this portion, we discard a certain amount without accurately and consistently stating the criteria; (3) of what we keep, we record what is most readily understood; and (4) of this residuum we publish only what we consider important. No scholarly discipline can accept such standards as scientific.

8. *Objectivity of record*

Goal of our excavation methodology is to strive towards a theoretically more defensible level of objectivity. I consider such objectivity to derive more from method than from techniques, though the latter are indispensable. Electronic data processing, in particular, is assumed as an essential technique, but objectivity is not in the computer as such. The following two points spell out my basic methodological presuppositions.

9. *Primacy of atomistic observations*

Observations can only be at the level of discrete, single facts. We do not observe syntheses, but only discrete details as they emerge from the ground. We must give absolute primacy to these details, by training ourselves to observe them in the first place, and then by having adequate means of recording them.

10. *Irreplaceability of original observations*

The original atomistic observation is the basic fact of the stratigraphic record, and should never, ever be jettisoned. We must both record it properly and preserve it faithfully forever.

The quality of the observation is proportional to the skills of the observer, hence each original observation must remain linked to the person and the moment of the original notation.

11. *Global record*

A site report should not be a synthesis (just as a text edition is not a selection of the phrases the editor likes best). It must instead present the global record of all the observations made. The quality of the observation is proportional to the discerning power of the recording system: the underlying "grammar" insures that the record not be a dump of disarticulate, personal notes. Instead, the record must be "public" (hence publishable) even while it is being assembled (i.e. at the very moment of the excavation). Nothing can be added to it afterwards, and therefore mustn't. This too is the function of the "grammar."

12. *Feedback for strategy*

While obviously there are overarching cultural goals to an excavation, the primary responsibility of archaeologists *qua* archaeologists is the record, not the cultural goals (*qua* historians, anthropologists, statisticians, etc. they can do what they want after the record has been established). Our method must be so implemented as to provide ongoing feedback about the stratigraphic reality: this should be the primary feedback for alterations in the ongoing process of excavation.

13. *Explicitness about precision and strategy*

Standards must be defined explicitly, and choices made must be stated on an ongoing basis, indicating the ranges for which one has opted, the reasons why, etc.

One must be ready to change gears at any time, in terms of ranges of precision. The system must provide an ever more complete array of options, any of which can be chosen at any time.

		GENERAL SETTING ¹		Type of analysis
		A	B	
ARCHAEOLOG.	Locational	Emplacement/Context ⁴	Deposition ⁵	1. Stratigraphic
	ASSOCIAT.8	Intra-assemblage	Composition ⁶	Manufacturing ⁷
Non-locat.		Extra-assemblage	Dating,etc. ⁹	Function,etc. ¹⁰

¹Relationship to space or time as distributional referent

²Space arrangement, morphology.

³Time, causality, syntax.

⁴Disposition of single element in relation to contiguous space (emplacement) and to non-contiguous elements (context)

⁵Assumed development through which elements became embedded in the ground; "site formation" (inappropriate view of site as primary artifact)

⁶Patterned ordering of attributes among elements within same assemblage (shape, ware, etc.)

⁷Procedure implied, tools assumed to have been used



⁸Relationship to other elements as distributional referents

⁹Relationship to data derived from analysis of other data; bracketing; linkage; extrapolation

¹⁰Assumed use; assumed stylistic influences; assumed transfer through commercial exchange, etc.

¹¹Integrative analysis of archaeological and non-archaeological data

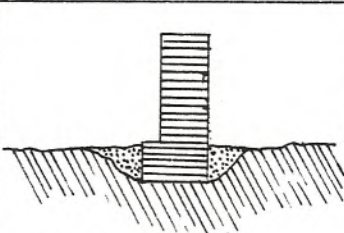
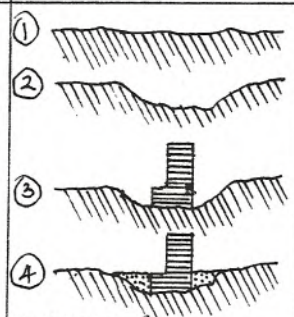
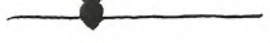
Examples

feature		item		
A	B	A	B	
				1
continuous degree of compaction along side of trench	sequence of stages	axis perpendicular to floor	pressed in floor	
soft fill, hard brick, compacted sides	shovel marks	grooves, firing, temper	wheel made	2
text inside fill dated in relationship to content of other texts	influence of foundation footings at other sites, contrast to walls without foundations	absence of type in earlier periods	used as drinking cup	3

TYPES OF CONSTITUENTS

- ELEMENT** minimal stratigraphic/typological constituent of data, defined as either stationary (features - e.g. wall, floor), or movable (items, objects, lots - e.g. blade, sherd lot)
- PARA-ELEMENT** an element which does not exist as such (stratigraphically), but is presupposed on the basis of direct evidence (generally an impression left on other elements: a peg's impression on a sealing), or indirect evidence (generally an argument, e.g. a wall assumed on the basis of a building's layout)
- REFERENT** minimal constituent of recording system, pertaining to either physical network (e.g. control point, relay), or analytical network (e.g. journal, photograph)
- INCIDENTAL** non-systemic unit of description, i. e. situations and events pertaining to chronicle details identified by appropriate specific label - e.g. sg (strategy to be pursued on a given day), dy (daily review of entire unit), we (weather as observed by given unit supervisor), sy (surveying as pertaining to given unit), etc.

STRUCTURE OF CONSTITUENTS

- CP COMPONENT** typological sub-unit of element (e.g. brick, sherd)
- ATTRIBUTE** one of several analytical traits which together define a constituent; it may be viewed either as variable or as variant
- VARIABLE** (or Roster Slot): structural category of element structure (e.g. color)
- VARIANT** (or Attribute State or Roster Entry): content of variable, typological or specific label (e.g. white)
- CLUSTER** grouping of elements or referents according to a given criterion (e.g. aggregate)

ORGANIZATION

- LABEL** alpha-numeric code derived from sequential log, which identifies uniquely any given constituent
- GENERIC LABEL (primary or first level of specificity)**
minimum stratigraphic/typological definition (e.g. feature, item)
- SPECIFIC LABEL (secondary or second level of specificity)**
intermediate typological definition (from lexicon of variants, e.g. wall, tablet)
- ROSTER** structural sequence of attribute slots (variables)
- LEXICON** list of attribute states (variants for variables)
- STANDARDS** parameters defining variants
implicit (e.g. "white" as common sense value) or
explicit (e.g. Munsell value)
- MATRIX** special configuration of roster, lexicon (and occasionally standards)
as interactive data entry sequence
- FORM** same as matrix, but in paper layout.

SUMMARY

Roster of Attrib.Slots variable	Lexicon of Attrib.States variant	Standards definition (explicit or implicit)
---------------------------------------	--	--

3. CONSTITUENTS: DEFINITIONS

ELEMENTS: TYPES

Feature	stationary element whose typological identity is tied to a place (e.g. wall, floor)
Item	movable element, whose typological identity is independent of place (e.g. blade, b-lot)
Object	manufactured item
Specimen	non-manufactured item, subject to count (e.g. a single stone)
Sample	non-manufactured item, non subject to count (e.g. soil)

PARA-ELEMENTS

Composite	normalized rendering of an item of which multiple exemplars exist
N Negative	a missing item, present as void and documented by the physical imprint it has left of part at least of its surface(s) on other element(s)
T Trace	a missing feature (same definition as for negative)
Zero	a missing feature, which is inferentially probable but has left no physical trace

ELEMENT CLUSTERS (or complex elements)

Lot	quantity of movable items (further specifiable as components), triangulated only as locus
Aggregate	cluster of elements, defined on the basis of depositional analysis (e.g. items on a floor)
Assemblage	cluster of elements, defined on the basis of typological analysis (e.g. walls, spouted jars)
J Join	stratigraphically distinct elements which are components of same typological elements

REFERENTS: TYPES

Marker	triangulation point set by surveyor; includes benchmarks (permanent markers) and control points (temporary markers used to measure relays)
Relay	triangulation point obtained by excavator
Section	a physical plane cut vertically through the deposition
Profile	analytical rendering of a section (an index to spatial relationships of elements contained in the volume through which the section is cut)
Stratum	minimal unit of reference relating spatial elements in terms of temporal sequence
Phase	intermediate unit of reference relating spatial elements in terms of temporal sequence
Horizon	maximal unit of reference relating spatial elements in terms of temporal sequence
View	window on constituent or cluster of constituents, giving an analogical representation by means of photography (in practice, every view is embodied in one or more photographs; alternatively, the term "photograph" refers to the physical embodiment of the view)
Drawing	analogical representation of measurements for a given constituent or cluster of constituents, by means of hand drafting - for permanent use
Sketch	same as drawing, but for temporary use
Graphic	analogical representation of digital information, by means of electronic processing of computer file(s)

REFERENT CLUSTERS

Locus	volumetric unit with minimal horizontal axis and unlimited vertical axis
Level	volumetric unit with minimal vertical axis and unlimited horizontal axis
Square	cluster of loci, with medium horizontal axis
Quadrant	partition of Square, introduced for reasons to be specified individually
Unit (operational)	cluster of squares, linked together logistically for operational reasons (e.g., A1)
Unit (typological)	cluster of squares, linked together typologically (e.g., AK) or functionally (e.g., BH)
Sector	partition of Unit, introduced for reasons to be specified individually
Operation	generic term for square, quadrant, sector or unit
Book	operational term for either Unit or
Area	topographical component
Digital file	cluster of relays, sorted typologically
Plot	cluster of digital files, reproduced graphically on screen or paper
Template	graphic overlay on view, identifying elements and referents, including especially secondary views (generally sketched on a print, but occasionally also on a drawing; see example below, 14)
"Web"	cluster of views, taken at the same time and pertaining to the same cluster of constituents, each view being taken from a different angle; all views are interlaced together on the same template
Main view	single view in a web, onto which secondary views are mapped as part of that view's template (e.g. v7)
Secondary view	a view within a web, for which no independent template is given, and which is instead mapped onto the template of the corresponding main view (e.g. v7a)

4. CONSTITUENTS: DESCRIPTIONS

PARA-ELEMENTS

Para-elements

The term refers to elements which exist only inferentially, but are nevertheless assumed to be real (on the basis, precisely, of a reasonable inference) and are not just imagined.

Composite

The definition of a composite as "normalized rendering" could be applied to a variety of situations, e.g., the extrapolation of surface lines in drawing a vessel, or wall, surface, is a normalized rendering.

However, the term is restricted to only such situations defined as pertaining to "items for which multiple exemplars exist"; the term itself, "composite," refers to such multiplicity rather than to the normalization which occurs.

A composite differs from a type in that it is assumed as a concrete single element, not as an idealized category.

Examples are a composite brick (rendered from either fragments or even complete but slightly different individual bricks), or a seal impression (rendered from a multiplicity of individual rollings)

Negative and Trace

The two terms are used only in order to have the benefit of different labels between items and features; they otherwise refer to the exact same concept

Either term refers to the mirror image of the original element (e.g. the impression of a basket on the back of a clay sealing): in this sense the negative/trace is the interface between the original element and the void which has taken its place. However, the term negative/trace refers not to this mirror image in a photographic sense, but rather to the fact that the element is not currently existent.

A *mold* is the physical embodiment of the outer face of the void (the envelope around the outer part of the interface).

A *cast* filling the void would give an accurate representation of the missing element (and would be a positive in a photographic sense).

To sum up:

negative/trace: original element, present only as void

imprint: interface left by element, now outer face of void

mold: physical embodiment of imprint, or physical envelope of interface (interface seen from outside)

cast: filling of void contained by interface, or copy of original negative/trace (interface seen from inside)

Examples:

trace: negative walls in AK

negative: objects on which sealings were placed, seals from which rollings were rolled, shovel marks.

Zero element

The term "zero" is used to stress the fact that no direct physical evidence is left of the element.

Only zero elements which are essential for discussion will be postulated, since there is otherwise no end to the number of zero elements that could be posited (e.g. door lintels, windows, etc.)

CLUSTERS (or complex elements)

Clusters

The difference between elements and clusters is in the degree of nesting established, or choice of parameters made, by excavator: bricks as components of wall, wall as element of aggregate. World is an aggregate; site is an aggregate, but neither susceptible of proper analysis. Wall is an element as appropriate unit of analysis. There is no element which is so metaphysically: it is only a relative function of nesting choices.

5. CONSTITUENT LABEL: RANKS

DEFINITIONS

Rank	Ranks							Full label	Computer dir\file
	1 project	2 section			3 element		4 component		
a	a	-	b	-	c	a	-	b	
library		book			label	seq#	label	seq#	
site, title	subsite	area/ typolVol	excvUnit/ filmType	operation/ operation/	element referent	seq# season	cmpnt roll#	seq# exp#	

ALLOWED RANGES

[AA	A	0	a	1 [] (*)	a	1	} (Rank 4 = type of film; 5 = season/batch Rank 6 = roll; 7 = frame)
...	
...	S,Z	Z	z	999	z	99	
[ZZ	V	A...Z	{1-...99z}	{01...99}	01...99		
[AA	A	A	0	a	1 [] (*)	a	1
...	
[ZZ	Z	S,Z	Z	z	999	z	99

EXAMPLES OF GENERIC LABELS (ELEMENT AND REFERENT)

MZ		B	1	f	1			B1f1	\MZ\B1\O\F\0001.A
				f	1	-b		B1f1-b	\MZ\B1\O\F\0001-B.A
				i	999			B1i999	\MZ\B1\O\I\0999.A
				q	10			B1q10	\MZ\B1\O\Q\0010.A
				q	10	-b		B1q10-b	\MZ\B1\O\Q\0010-B.A
				q	10	-p	1	B1q10-p1	\MZ\B1\O\Q\0010-P01.A
				r	1			B1r1	\MZ\B1\O\R\0001.A
		V	C	6	-		01	24	VC6-0124
		V	C	12	a		01	24	VC12a0124
MZ	O	B	1	q	10	-i	1	OB1q10-i1	\MZ\OB1\O\Q\0010-101.A

EXAMPLES OF SPECIFIC LABELS (-INCIDENTAL AND ^ELEMENT)

MZ		B	1	-dy			(*)		\MZ\B1\^-DY.A
				-we			(*)		\MZ\B1\^-WE.A
		Z	1	-pc			(*)		\MZ\Z1\^-PC.A
		B	A	^tb	99			BA^tb99	\MZ\BA\^TB.A (**)
				^we			(*)		\MZ\BA\^WE.A (**)
				^we	1			BA^we1	\MZ\BA\^WE.A (**)
		Z	1	^fg	999			Z1^fg999	\MZ\Z1\^FG.A (**)

(*) Where no element number is given (regularly with incidentals), the label is found not for a particular constituent, but only as the title of a given file; thus BA\^WE.A is a file dealing with BA weapons in general, BA\^-WE.A a file dealing with weather as observed by BA supervisor, etc.

(**) There are no files named after individual specific label elements (thus, no -WE-001.A; individual specific labels occur in the form of an index under, e.g., -WE.A and then under each respective generic label.

6. DIRECTORY OF COMPUTER FILES: EXCAVATION UNITS

COMPUTER DIRECTORIES

A1 ~ SZ	I	J	journal data entry	J(-A/B/C/...)
			wrong entries from .J files	!.
	E		full file with correct and wrong entries	.
			entry point into archive	.E
	O	-	incidentals	.A
		A	aggregates	.A
		B	benchmarks and markers	.A
		C	control points	.A
		F	features	.A
		G	graphic (digital)	.A
		I	items	.AG (archival graphic format)
		J	join	.A
		K	loci	.A
		N	negative	.A
		Q	lots	.A
		QB	bone lots	.A
		QI	item lots	.A
		QP	pottery lot	.A
		QV	various lots	.A
		R	relays	.A
V		views	.A	
Z	temp.file for other books	.Z		
X		indices		
	xdp	depositional synopsis	.X or .X#	
	xdf	index by definition	.X or .X#	
	xq	index of lots	.X or .X#	
	xsf	index by sr/ft	.X or .X#	
	xf	index by ft/sr	.X or .X#	
	xl	index by generic label	.X or .X#	
	xl	index by generic label	.X or .X#	
	x^lb	index by specific label	.X or .X#	
T		text files		

BOOKS ONLY

A1 ~ SZ	{	vt	view/template	(# = sequential number)
		wf#	drawings of features	(# = page number)
		wi#	drawings of items	(# = page number)
		wq#	drawings of q objects	(# = page number)

RANK 5**INCIDENTALS AND STRATIGRAPHIC ELEMENTS**

<i>if rank 3 = A - S, Z</i>	B1f1, B1.34, B1q999
- specific label for incidentals (chronicle details)	
a aggregate	
f feature	
. item (i is used in computer labels as a replacement for .)	
q lot (abbreviation stands for "quantity of movable items")	
s stratum	
^ specific label for elements	

REFERENTS OF PHYSICAL NETWORK

<i>if rank 3 = A- S, Z</i>	B1k3, A1r152
k locus	
r relay	

<i>if rank 3 = Y</i>	Y1b3, Y1c103, Y1m152
b benchmark (third degree precision)	
c control point (fourth degree precision)	
m marker (= benchmark/control point)	

REFERENTS OF ANALYTICAL NETWORK

<i>if rank 3 = A - S, Z (computer file/page number)</i>	B1p3, B1h42, B1\J\A501.J, BA\T\SM.A6B
g graphic (digital file)	
h handwritten original of j (books only)	
j journal	
p page (books only)	
t text (free format)	
v view	
x index	
w drawings	

<i>if rank 3 = V (photo binders and individual frames/slides)</i>	VC60235
a archive	
b b/w negative	
c color slide/negative	
d "direct" slide (Polaroid slide)	
e extra-large, black/white	
f extra-large, color	
n negative - polaroid	
p print - polaroid	
s special	

RANK 7**COMPONENTS OF ELEMENT**

<i>Features</i>	B1f1-b or B1f1-b1 (brick or brick 1)
-b brick	
-m mortar	
etc. (see under LEXICON OF VARIANTS)	

<i>Lots</i>	B1q999-p or B1q999-p9 (pottery or pottery sub-lot 9)
-b bones	
-o objects	
etc. (see under LEXICON OF VARIANTS)	

HANDWRITTEN NOTES

Volume and page number are an absolute necessity on every page of your handwritten notes; since we operate with loose leaf binders, omitting that information causes innumerable problems when dealing with isolated pages

Initials and date in coded form are fundamental to the system, and must always be included

Every single drawing must be accompanied by a graphic scale (generally 5 cm for objects)

The format for labels must be adhered to scrupulously: spaces, dashes, punctuation, upper/lower case, all have meaning and must be used according to directions

See below, under Utilities, for a list of important details on practical aspects of handwritten notes

Handwritten filelogs are a strict requirement, and should accompany every disk at all times

COMPUTER DATA ENTRY

File name

extension must be .J (or .J-A, see presently)

format is otherwise free (within DOS limits), but it is strongly recommended that the following format be used:

1234 extended date

567 initials (-)

8 sequential number, e.g.:

D623RAH

F707RAH1

F707RAH2

F702GB

C630RK-1

Corrections on existing files are marked by a letter added in the extension after a hyphen, e.g.

D707RAH1.J-A

D707RAH1.J-B

File maintenance

disks (masters and back-ups) are assigned to each individual, and it is the individual's responsibility to maintain files and directories on the disk throughout the season

disks must be turned in regularly (to GB or FAB) for what we call "Entry point" into the system: files are checked for format accuracy, and returned for correction if necessary, until they are accepted

acceptance is signaled by a change of the .J extension to .E extension (for Entry point)

if files need corrections, the disk is returned with two new files added to it: one file with extension .- contains the same text as

the .J file, with a note added after each incorrect occurrence; a second file with extension .! contains only a list of errors

you must keep working on corrections until the extension is changed to .E; from that point on, files have entered the main system and are no longer your responsibility

it is imperative that there be no handwritten notes left by the end of the season: it is your responsibility to make sure that everything for which you are responsible is entered and proofread

File log

there must be a text file labeled -FL (for INCIDENTAL: FILE LOG) on every disk produced and maintained

the file is updated regularly, with each new file that is produced, and is copied from the file log form

the -FL file gives the label and describes briefly the content of each corresponding file

a file labelled -FP (for INCIDENTALS: FILES PROCESSED) is generated by the program that accesses files at the Entry Point, as is maintained within the overall system

(NB. This is a "poor man's" equivalent of networking.)

BASIC CONCEPTS

Data entry types

the *Journal* is the combination of three major types of data entry:

- (1) the *diary* corresponds to the descriptive part of the journal, and cannot include tabs
- (2) the *log* corresponds to the tabular format of the log forms, and includes tabs in the proper sequence
- (3) the *list* includes a variety of options with and without tabs, not corresponding to the logs

the three types of data entry may be mixed within the same journal file, though it is preferable to keep them separate for the purposes of data entry

File level codes

all codes for "file" are considered as "headers," because they generally occur at the beginning of a file

the following two entries must be in first and second position

a file label entry (required) repeats the file name

a file note describes in brief the content of the file (required)

date and recorder's initials are required at beginning of each file; may be repeated at any time within file

other headers are optional

header level codes are common to each type of data entry

Record level codes

all data pertaining to a single constituent are considered as being part of a single "record"

the format differs depending on the type of data entry

Field level codes

individual attribute or roster slot

the format differs depending on the type of data entry

DIARY TYPE

Record format

a record is identified by a single letter code at the very beginning of an entry

incidentals are identified by - or ^ followed by a two letter code at the beginning of an entry

a blank line is not required but may be inserted between each record for ease of proofreading

following the record identifier entry there can be as many field entries as needed

Field

a field is identified by a double letter code at the beginning of an entry

the double letter code is either sequential (upper case letter followed by digit or lower case letter)

or else it is mnemonic (two lower case letters)

Field structure

fields are written as a single paragraph, introduced each by the two letter code followed by a space

the RETURN key signals the end of the field/paragraph, hence it can only be used at the end of a field

there can be no tabs within a field of the diary type

unless otherwise indicated, the length of a field is practically unlimited (32000 characters is the maximum)

numeric fields can only contain digits (without commas or letters)

reduced fields can not be longer than the max length indicated in pointed brackets in the main roster

special format requirements are required for the following fixed fields:

equal sign for labeling

depositional process

analogical record

10. STRUCTURE OF JOURNAL: LOGS AND LISTS

SYMBOLS USED IN FOLLOWING EXAMPLES:

^ = tab
 < > to identify entry
 \$ \$1 \$2 refer to variables

LOG ENTRY FOR FEATURES, LOCI, AGGREGATES, ITEMS, LOTS

enter a tab for each column in the form, whether or not there are data for that particular column
 tabs for blank columns to the right are omitted
 the constituent identifier (e.g., f for features) is placed at the start of each sequence, followed by carriage return

LOG ENTRY FOR STRATA

s
 # #[, #, #]
 #-# #
 #a #

must have s before first stratum number
 there must be one tab only
 feature number, without f prefix, on right
 there may be more than one feature, divided by commas only
 there may be hyphens between strata (not slashes)
 there may be a postfix letter after strata
 do not use question mark for uncertain stratum assignment; use double hyphen

LOG ENTRY FOR RELAYS

<r> identifies log entry sequence as belonging to relay sequence (begins record)
 <cl f26> (constituent label to which relay applies) - carried over within relay mode
 <mm t> method of measurement (t=taped; k=known) - carried over
 <o1 m1181> origin of tie 1 - carried over until changed
 <o2 k119f> origin of tie 2 - carried over until changed

if mm=t then log entries are:

<125	^naill	^NWcrnr	^324	^766	^8535	^86>
<	-	-	-	-	^m1181	^86>
r	rf	rl	t1	t2	oe	te
REQ.	REQ.	OPT.	REQ.	REQ.	OPT.	OPT.
			NUM.	NUM.	(*)	NUMERIC

(*) if absolute value, then numeric; otherwise letter indicating marker from which relay is measured (its elevation is to be gotten from the C directory)

if mm=k then log entries are:

<r125	^naill	^NWcrnr	^45301	^32001	^8492>
r	rf	rl	nc	ec	el
REQ	REQ	OPT	REQ	REQ	OPT

LIST TYPE

<list1>
 <\$1 ^\$2 \$3> declares that each element \$1 (contained within following list)
 contains the entry \$3 (e.g., storage box 29)
 in roster slot \$2 (e.g., roster slot P2)

<32>
 <33>
 <10>
 <2>
 <104>
 <endlist>

<list2>
 <\$1 ^\$2> declares that following data entries are in single tab format, with
 \$1 = record header (e.g., i for item)
 \$2 = field header (e.g., O2 for best photo)

<1^B0312>
 <1a^B0317>
 <endlist>

11-SDIAR.G6M

11. SAMPLE JOURNAL ENTRY: DIARY

.bk A6
 .fl C7-1-D,J
 .fd conflation (1) of diary files, M27
 .ei gb
 .ed G617
 .fn edited for format by GB, G617

.fl C705RK.J

rd C704
 ri rk
 f 1
 tc ov f5
 tc ov f16

f 4
 tc cu f1
 tc ov f5

f 17
 pr a section was cut along the W face of f17 (see v02). This showed no significant stratification to the level excavated tot eh E of A1f66 (i.e., ca. 50cm now).

f 5
 tc ab f16

-sf ST is recovering from illness and worked at home today.

-wk today's operation in A6 involved 6 pickmen (3 large, 3 small) and 9 supporting hands

k 217
 dy more soil removed today, more 30cm across. The locus was cut as a step, at 2 levels.

f 17
 dy was excavated W to E to a depth of 5cm to expose any brickfaces to the N and S. A rabbeted brick wall appears on the N.

-dy 2 intact jars (2nd mill?) were recovered from close to the surface from the NE corner of k218. The rabbeting of the brick wall along the N baulk of k168 is interesting.

rd C705
 ri rk

-sf ST back on field

f 2
 tc ov f7
 tc ov f10
 tc ov f12

-sf ST worked on objects processing at home after the morning break.

-wk we had several more workmen today than yesterday that excavation could be carried on to some degree in all 6 loci: 5 large picks, 4 small picks + support.

-dy GB's analysis that there is another closet past the doorway in k168 parallel to A1a1 is partially corroborated.

--i we currently have 6 squares open. 3 of them are past topsoil, into the level of hard ac or brickfall (k167-169), the other 3 are new from which all topsoil has not yet been removed. RK and ST have primary responsibility to supervise work in this area.

-sg our strategy has to take into consideration the number of workmen and tools available along with the need to analyze the current strata of some loci better before proceeding with much more work there. -- [A] Since k217-219 are being opened for excavation, removal of topsoil there has priority and can be carried with minimal supervision. Currently k217 has been cut into 2 steps since it is on EW downward slope of the tell. The upper (E) half will be made level (the SE quadrant has not been lowered yet) and then soil will be removed for another 30cm throughout (barring unexpected finds). -- [B] It seems to us that further excavation in k167 can help us answer some important questions such as: (1) if the rabbeted face of brick is one side of a doorway, what does it open into? (2) is there a room N of k167 or is what we have the outer wall? note: k117 N of the wall f78 did not contain any significant cultural artifacts, ac, floor, etc. (3) wall A6f16 is >2m broad so that it could very well be an outer wall; (4) digging further down might help us to see if the flat rock, with brick below it, in the NE corner of k167 is part of a structure. So we shall consult with GB about digging down in f5. Perhaps one or two workmen can be assigned here to dig with the small pick. -- [C] The floors of k168,169 need to be scraped, scored before further excavation. -- [D] The remaining workmen shall be assigned to k218 to remove topsoil until k219 is scraped and studied.

v 1
 vg shows emplacement of skull in f7

v 1a
 vg closeup of emplacement of skull in f7

v 2
 vg shows section of f17 with context

ed C710
 rd C704

f 1
 A1 A1f124

f 2
 A1 A1f129

f 3
 A1 A1f130

12. SAMPLE JOURNAL ENTRY: LOGS

Note. ^ stands for tab

.bk A6
 .fl C7-1-L.J
 .fd conflation (1) of log files, MZ7
 .ei gb
 .ed G617
 .fn edited for format by GB, G617
 .fl C705RK.J

rd C704
 v
 1 ^ ^ ^ E ^vf 2,7,10,12 / vk 168
 2 ^ ^ ^ E ^vf 2,7,12,17,A1-66 / vk 168
 3 ^Y ^ ^ NE ^vk 218,217 / vf 14,13 / vi 1,2
 3a ^ ^ c ^NE ^vi 1,2
 4a ^ ^ ^down ^A1,A6 --kite photos
 4b ^ ^ ^down ^vk 168 --kite photos
 7 ^ ^ ^ E ^vk 168 / vf 2, 7, 17, 12, 20 / vi 32

a
 1 ^k168 ^closet ^ ^N of k168
 2 ^k170 ^doorway ^ ^with drain f74
 3 ^k169 ^doorway ^ ^between k169 & 168
 4 ^k168 ^doorway ^ ^between k168 & 218

f
 1 ^167 ^3 ^topsoil
 2 ^168 ^3 ^topsoil
 3 ^169 ^3 ^topsoil
 4 ^167 ^1 ^gulley wash
 5 ^167 ^6b ^ac ^red layer below gulley wash
 6 ^169 ^9 ^ac + brickfall ^below topsoil
 7 ^168 ^9 ^brickfall ^E part of locus
 8 ^169 ^12c/13c ^wa ^along N of locus

rd C704
 i
 1 ^ ^014 ^ja ^14 ^ ^14 ^ ^c ^ ^buff ^intact except
 for rim
 2 ^ ^014 ^ja ^ ^ ^ ^c ^ ^buff ^intact

rd C706
 3 ^ ^013 ^se ^1 ^3 ^2 ^ ^c ^ ^black ^hard
 4 ^ ^023 ^needle? ^ ^7.5 ^0.2 ^ ^m ^ ^

rd C707
 5 ^ ^023 ^vr ^ ^6 ^1 ^ ^m ^ ^rod
 6 ^ ^023 ^to ^ ^4 ^1.5 ^ ^l ^ ^flint blade ^

k
 167 ^ ^400N ^400W ^square E of ASK117
 168 ^ ^400N ^400W ^square S of k167
 169 ^ ^400N ^400W ^square S of k168
 217 ^ ^400N ^400W ^square E of k167

k 217
 n1 100 and 200 series locus lables are derived from
 original AS labels

k
 218 ^ ^400N ^400W ^square S of k217
 219 ^ ^400N ^400W ^square S of k218

ri AP
 q
 76 ^p ^ ^024 ^168
 77 ^pbl ^ ^017 ^168 ^ ^ ^ ^ ^flint
 78 ^p ^ ^023 ^217
 79 ^op ^ ^014 ^218
 80 ^gop ^ ^022 ^219 ^ ^ ^ ^ ^o:snail shell, g: kiln
 waste from NW quadrant
 81 ^p ^ ^014 ^218
 82 ^p ^ ^014 ^218

s
 B3 ^1
 B3 ^2
 B3 ^3
 B1 ^4
 B6b ^5
 B9 ^6
 B9 ^7
 B12c-13c ^8
 B9 ^9

13. SAMPLE JOURNAL ENTRY: LISTS

Note. ^ stands for tab

```
.bk ZS
.fl F608RAH
.fd storage
.ei rah
.ed F608
```

```
list1
l      ^P2 29
```

```
A1.007
A1.014
A1.015
A1.018
A1.020
A1.021
A1q167-l
A1q181-g
A1q183-i
A3.002
A3.003
A3.004
A3.006
A5.001
A5.002
A5.005
A5.006
A5.007
A5.011
endlist
```

```
list1
l      ^^P2 30
```

```
A5q143-l
A5q147-l
A5q149
A5q150-l
A5q152-b
A5q156-b
A5q156-i
A5q156-l
A5q158-l
A5q160-l
A5q173-s
A5q181-l
A5q181s
A5q191-b
B1.127
B1.128
B1.129
B1.132
B1.133
B1.134
B1.136
BHq528-i
BHq529-i
BHq545
Bhq572-1
C1q085-p
F1.0-1
F1.017
F1.030
F1.038
endlist
```

```
.bk A6
.fl E712W
.fd list of drawings
.fn Initials are those of Ibrahim Hellu. This
   file contains all items drawn for
   buildibg AK (i.e. A1, A5, A6). They are
   categorized by items and lots.
```

```
ei ibr
ed E712
```

```
list2
i      ^rw
1      ^MB - C708
2      ^CH - C708
5      ^JB - D629
9      ^JB - D702
14     ^JB - D627
17     ^JB - D702
```

```
q73-o  ^CLH - D727
q114-0 ^CLH - D702
q130-m ^JB - D629
q166-o ^JB - D704
q260-o ^RPK - 623
endlist
```

```
.bk ZZ
.fl F522-LPH.J
.fd list of photos from prints
.fn entered in Vienna
.ei gb
.ed F515
```

```
list2
l      ^O2      ^ph
```

```
A1.8   ^E4804
A1.20  ^E6011  ^this photo shows detail well
A1.20  ^E4102  ^E6011 is better for detail
A1.45  ^E0909
A1.57  ^E0811
A1.68  ^E6104
A1.77  ^E6007
A1.78  ^E2712
A1.79  ^E0904
A1.96  ^E1909
A1.102 ^E0802
A1.106 ^E1711
```

```
A5.10  ^E4612
A5.10  ^E46(??)
A5.25  ^E4807
A5.25  ^E4809
A5.30  ^E4711
A5.34  ^E1512
A5.37  ^B0716
A5.42  ^E0309
A5.46  ^E6609
A5.46  ^E6510
endlist
```

14. MAIN ROSTER: IDENTIFICATION OF SLOTS

Codes: numeric only {#}
 fixed format {F}
 required {R}
 max length in characters {4}
 E = element
 R = referent
 ● generated by program, do not enter
 anywhere after fixed or numeric format:
 @ introduces note on particular entry

HEADER

.bk book {RF}
 .fl file label {RF}
 .fd file definition {R}
 .fn file note
 .ed entry date
 .ei entry initials
 .rd recording date {R}
 .ri recording initials {R}

CONSTITUENT (RECORD)

INCIDENTALS (MAIN AREA)

..** chronicle
 ** = specific label (e.g. -sg)

ELEMENTS (MAIN AREA)

a aggregate {4}
 f feature {4}
 i item {4}
 q quantity lot {4}

PARA-ELEMENTS (MAIN AREA)

c composite {4}
 j join {4}
 t trace {4}
 z zero {4}

REFERENTS (MAIN AREA)

d digital {4}
 k locus {4}
 m marker {4}
 p plot {4}
 r relay {4}
 s stratum {4}
 v view {4}
 w drawing {4}

COMPONENTS

element or para-element
 followed by -## {4-2}

ALL LABELS (OTHER AREAS)

l full generic label

ATTRIBUTE (FIELD)

1. IDENTIFICATION

A. LABELING

ER =1 A1 equals other label {F}
 >1 A2 includes other label {F}
 <1 A3 included under other label {F}
 o# A4 other field number {F}
 sp A5 typological specific label {F}
 A6 publication number
 nl A99 notes on labeling

B. DESIGNATION/COUNT

ER df B1 definition (or typological label) {20}
 ds B2 description: summary of entire record
 qc B3 quantity of components {#}
 B4 list of components
 nq B5 quantity notes
 nd B99 notes on designation

2. STRATIGRAPHY

C. RECOVERY

E dy C1 daily notes on recovery of element
 sg C2 strategy (projected or implemented)
 ar C3 argument
 pr C4 procedures
 op C5 options (alternatives)
 ac C6 accidents
 nr C99 notes on recovery

D. VOLUMETRIC LOCALIZATION

E lc D1 locus (also grid square if needed)
 lv D2 level
 ● D3 relays (applicable to elements)
 ne D4 North coordinate of relay
 ee D5 East coordinate of relay
 el D6 elevation
 rf D7 relay definition
 cl D8 constituent label to which relay applies
 rl D9 relay location on element
 mm D10 method of measurement
 o1 D11 origin of tie 1
 o2 D12 origin of tie 2
 oe D13 origin of elevation
 t1 D14 tie 1
 t2 D15 tie 2
 te D16 tie of elevation
 ● D17 reference to digital files
 ● D18 reference to plot files
 rp D19 ref. to plans, drawings, sections (W-files)
 nv D99 notes on volumetric localization

E. AXIAL DEFINITION

f sl E1 slope (degrees/direction)
 i in E2 inclination
 or E3 orientation
 ro E4 rotation
 na E99 notes on axial definition

F. CONTACT ASSOCIATION

f bo F1 boundaries {F}
 tc F2 type of contact {F}
 ab abuts
 bo bonds
 ca caps + label
 co covers of depos.
 cu cuts object
 in intrudes
 le leans e.g.
 ov overlays tc re f71
 re rests on
 si sits in
 nc F99 notes on contact association

G. SPATIAL AGGREGATION

E ● G1 aggregate (to which element belongs)
 a >a G2 elements included within aggregate
 G3 nature of association
 G4 criteria for aggregation
 G5 element preserving interface of t
 G99 notes on aggregation

H. DEPOSITION

E H1 definition of process(es)
 H2 evidence
 H3 assumption
 H99 notes on deposition

I. TIME SEQUENCING

E ● I1 stratum (to which element belongs) {F}
 s >s I2 features included within stratum {F}
 I3 phase
 I4 horizon
 I5 absolute time determination (C14, date...)
 ns I99 notes on time sequencing

3. TYPOLOGY

J. MEASUREMENTS

E ht J1 height {#}
 lg J2 length {#}
 w1 J3 width-1 or diam. of rim {#}
 w2 J4 width-2 or diam. of body {#}
 w3 J5 width-3 or diam. of base {#}
 sz J6 size/other {#}
 th J7 thickness {#}
 i wt J8 weight {#}
 ca J9 capacity {#}
 rw J10 reference to drawings (W files)
 J11 reference to special records
 E nm J99 notes on measurements

K. DESCRIPTIVE

E cp K1 components (within element)
 di K2 distribution (compts w/in elmnt)
 wm K3 ware or material, species
 sh K4 shape, form
 co K5 color
 c# K6 color number (Munsell)
 hd K7 hardness, compaction
 tx K8 texture, surface finish
 de K9 decoration
 cn K10 condition
 pv K11 preservation
 i if K12 iconographic definition
 is K13 iconographic description
 sc K14 scene
 st K15 style
 ip K16 inscription
 E nt K99 notes on typology

L. MANUFACTURING

E L1 evidence
 L2 assumption
 L99 notes on manufacturing

M. FUNCTION

E M1 generic function (1st dgr specificity)
 M2 space definition (second degree)
 M3 activity definition (second degree)
 nf M99 notes on function

4. TREATMENT

N. CONSERVATION/ANALYSIS

i N1 needs observed
 N2 procedures employed
 N3 results obtained
 N4 transmittal (to lab)
 N5 reference to laboratory report
 N99 notes on conservation or analysis

5. REFERENCE

O. ANALOGICAL RECORD

v ● O1 view
 ● O2 best photo
 ● O3 other photos
 vg O4 view - general description
 va O5 view of aggregate {F}
 vf O6 view of feature {F}
 vi O7 view of item {F}
 vq O8 view of lot {F}
 vk O9 view of locus {F}
 vm O10 view - miscellaneous {F}
 vr O11 view range
 vo O12 view orientation
 ph O13 general notes on photos
 O14 other analogical record
 O99 notes on analogical record

P. DISPOSITION

ER P1 removed (ft), discarded/missing (item)
 P2 storage
 P3 seq. transmittal number to Museum
 P4 Museum number
 P5 laboratory number
 ER P99 notes on disposition

Q. PUBLICATIONS AND FILES

E tf Q1 reference to text file
 Q2 typological data bases
 Q3 project publications
 Q4 other publications
 Q99 notes on references

COMPONENTS (FOR SLOT *f* or *q*)**FEATURES**

-b brick
-m mortar
-p plaster
-v various

ITEMS and LOTS

-b bones (e.g. A1q3-b or -b# or -b##)
-c clay lump
-d bead
-f figurine
-g glass
-h shell
. item (A1q345.#)
-i item (A1q345-i#: variant for computer label)
-i lithics
-m metal
-p pottery
-s sample
-v various, light
-w various, heavy (weighty)

ELEMENTS**DEFINITION** (FOR SLOT *^* or *df*)**Features and Aggregates**

*^*a1 ac above floor surface ("living floor")
*^*a2 ac above a1, same type as a1
*^*a3 ac not above floor, e.g. abandonment
*^*a4 natural ac (i.e. sedimentation)
*^*a accumulation
*^*ba band (horiz. deposit with sharp lower and merging upper boundaries; see *ly*)
*^*be bench
*^*bf brickfall
*^*bn bin (~aggregate)
*^*bu burial (~aggregate; not built-up, see *gv*, *hb*)
*^*cr corridor (~aggregate)
*^*d doorway (~aggregate)
*^*f floor surface in general
*^*f1 floor, type 1 (plastered or lined)
*^*f2 floor, type 2 (highly compacted)
*^*f3 floor, type 3 (medium compacted)
*^*f4 floor, type 4 (compacted naturally)
*^*fi fill
*^*gv grave (~aggregate: built-up, see *bu*, *hb*)
*^*he hearth (~aggregate)
*^*ho hole
*^*hs house (~aggregate)
*^*ia item aggregate (e.g. vessels on floor)
*^*is installation (~aggregate)
*^*ki kiln (~aggregate)
*^*l1 lense type 1 (= floor, not bounded by wall)
*^*l2 lense type 2
*^*l3 lense type 3
*^*l4 lense type 4
*^*ly layer ((horiz. deposit with sharp lower and upper boundaries; see *ba*)
*^*or organic refuse
*^*ov oven (~aggregate)
*^*p1 coating (heavier than *fl*: cement, bitumen)
*^*p2 large components (flagstones, bricks or tiles)
*^*p3 small components (pebbles, sherds)
*^*pf platform
*^*pt pit (~aggregate)
*^*pv pavement (floor defined structurally by distinct surface elements)
*^*rf roof and roofing material

*^*rh rodent hole
*^*r room (~aggregate)
*^*so soil
*^*s structure (~aggregate)
*^*ta tannur (bread oven; ~aggregate)
*^*tr trench, trough
*^*ts topsoil
*^*uk unknown
*^*vr varia
*^*w wall

Items

*^*ar arrowhead
*^*ah ash
*^*as assemblage
*^*aw awl
*^*ax ax(head)
*^*ba bone artifact
*^*bd bead
*^*bk brick
*^*bl blade
*^*bo bowl (rim/height: 3/1)
*^*board (as on back of sealings)
*^*bt bottle (rim/height: 1/5)
*^*ca clay artifact
*^*cs carbon sample
*^*cl clay lump (and possible tablet)
*^*cv ceramic vessel
*^*di dish (small platter)
*^*e epigraphic
*^*fg figurine
*^*g glyptic
*^*go goblet (proportions as for small jar)
*^*hb human body (see *bu*, *gv*)
*^*in inlays
*^*ja jar (rim/height: 1/3)
*^*je jewelry item
*^*la lithic artifact
*^*ma metal artifact
*^*peg
*^*pi pin
*^*po pot (rim/height: 1/1)
*^*pl platter (rim/height: 5/1)
*^*qb, *qp*, etc.: see under lots
*^*ro root
*^*s sample (non-count, see *sp*)
*^*sc sculpture
*^*se seal
*^*sg slag
*^*sh spearhead
*^*si seal impression
*^*spoon
*^*sp specimen (count, see *sa*)
*^*string
*^*su statue
*^*t tablets (see *ep*)
*^*to tooi
*^*uk unknown
*^*vr varia
*^*vs vessel
*^*wa wood artifact
*^*we weapon
*^*wh wheel

MATERIAL (FOR SLOT *D3=wm*)

bn bone
cl clay
gl glass
ob obsidian
sh shell
li lithic
mt metal
wd wood

INCIDENTALS (FOR SLOT *-*)

-i introduction
-ae aerial photography
-cy city scenes
-dy daily
-eh expedition house
-el expedition life
-eq equipment
-fl file log
-fn fauna *animal*
-fr flora *plant*
-hl health and medical
-id individuals
-iv inventory
-ib labeling
-lg log
-is landscape
-mk marker
-mt methods and techniques
-nm name, address, references
-ny next year
-oa official activities
-ov overall shot
-pc people and customs
-ph phase
-pr public relations (excludes visitors)
-pw public works
-rs record shot
-sf staff
-sg strategy
-sn section
-so site overall
-sp special project
-sr strata description
-st storage
-su summary
-sy surveying
-tr transmittal
-tv travel
-vb village buildings
-vg village, general
-vr varia
-vs visits and visitors
-wa work activities
-we weather
-wk workmen
-zx site general, excavations

DEPOSITNL VERBS (FOR SLOT *dp*)

- 1 pit *cuts* floor (truncation)
pit *intrudes* fill (insertion)
- 2 jar *leans* agnst wall (partial contact at top)
jar *rests* on floor (partial contact at bottom)
- 3 floor *abuts* wall (adjacency of edges)
wall *bonds* with wall (interlocking of edges)
- 4 fill *covers* wall (total superposition)
brick *overlays* pit (partial superposition)
- 5 lid *caps* jar (matching of edges)
jar *sits* in pit (matching of sides)

TEXT FILES (FOR FILE NAMES *t-*)**FILE NAME**

use same codes as for incidentals

EXTENSION=GENERATION

use compressed date formula given below, U-1

For Stratigraphic Roster category sh (Shape)

Overall Shape

ob	bowl	(rim > height)
oc	cup	(small bowl)
oj	jar	(rim < height)
op	pot	(rim = height)
opl	platter	(rim >> height)
os	stand	no solid base
ox	other	describe

Rim

rh	hole mouth
ri	inturned
ro	outturned
rs	straight
rx	other

Base

bf	flat
bfv	flat, slightly concave
bfx	flat, slightly convex
bhf	high footed
blf	low footed
bp	pointed
bring	ring
bround	rounded
bsp	slightly pointed
bx	other

Handle







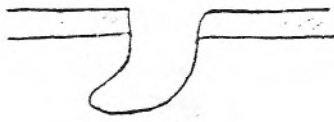

hitab	interior triangular tab
hlug	triangular lug
hsc	small semi-circular
hsh	strap handle
htab	tab

Other

x1	interior ledge for holding cover
x2	interior groove
x3	other

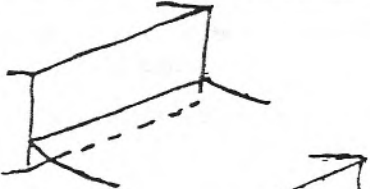
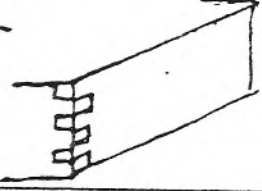
17. LEXICON OF DEPOSITIONAL VERBS

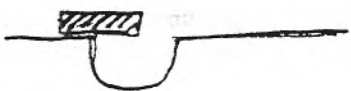
Note. Verbs are listed in the order of the absolute depositional sequence. At the top is the last, and at the bottom the earliest, process which can affect the object.

1a		pit <u>cuts</u> floor	(truncation)
1b		pit <u>intrudes</u> fill	(insertion)
2a		jar <u>leans against</u> wall	(partial contact at top)
2b		jar <u>rests on</u> floor	(partial contact at bottom)
3a		floor <u>abuts</u> wall	(adjacency of edges)
3b		wall <u>bonds with</u> wall	(interlocking of edges)
4a		fill <u>covers</u> wall	(total superposition)
4b		brick <u>overlays</u> pit	(partial superposition)
5a		lid <u>caps</u> jar	(matching of edges)
5b		jar <u>sits in</u> pit pottery <u>sits in</u> fill	(matching of sides)

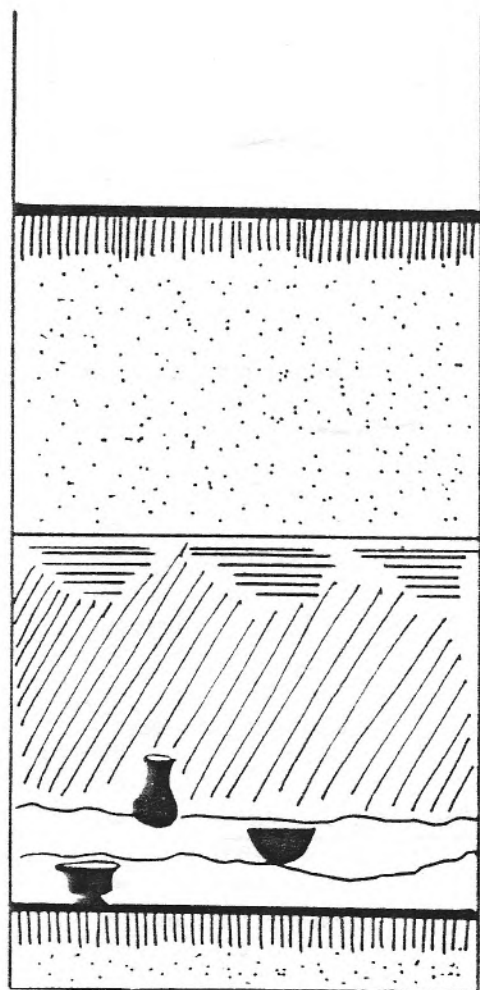

Floor emplacement

- [Floor compacted surface, possibly with thin plaster
- [Pavement hard, finished cover or coating laid upon floor

Floor preparation

- [Subfloor hard layer suitable for compaction
- [Fill soil (relatively clean, but also with certain inclusions, including ash and charcoal), dumped intentionally at a single point in time
- [Levelling flattening of preexisting debris

Accumulation above floor

- [Destruction reduction of preexisting deposition by human agents
- [Erosion reduction by natural agents

- [Sedimentation precipitation of natural material, such as windblown sand or organic particles, laminated through compaction into secondary floor surfaces or lenses

- [Occupation debris of human activities, including organic material, artifactual fragments, ash and charcoal, etc., laminated (as above)

- [Living floor presumed to have been in use during original occupation

- [Aggregate cluster of artifacts, presumed to have been deposited at the same time in a single location

- [Installation functional aggregate

Floor emplacement

[resumes cycle]

PHOTO LOG

LABEL give only one label; if there is more than one element, then use only view

SETTING direction toward which camera is pointed, or studio
 n,e,s,w north, east, south west
 ne,nw,... northeast, northwest, etc.
 nne,... north-northeast, etc.
 ov direct overhead
 on, one,... oblique overhead looking north, northeast, etc.
 st studio
 √ studio

RANGE c close-up (detail inside subject)
 t tight (no setting beyond boundaries of subject, tight boundaries, near shot)
 m medium (partial setting beyond boundaries)
 w wide (setting outside boundaries, far shot)
 fn far shot (telephoto), narrow
 fm far shot (telephoto), medium
 fw far shot (telephoto), wide

DESCRIPT. definition or brief description; some significant related labels.
 The main purpose of this entry is to help identify photo from photo-log; main archaeological information should be given in archaeologist's journal

PHOTO RATINGS AND CONVERSION

Exposure sequential number of shot as shown on counter of camera

Frame sequential number of shot as shown on film after development

It is generally sufficient to circle the best frame; for finer qualifications, the following categories may be used.

SIGNIFICANCE: overall importance and quality

- a good/excellent
- b documentary value: good
- c documentary value: poor
- f total reject, discarded

COMPOSITION: framing of subject

- a best ... c poor

FILMIC QUALITY: light, focus, color, ...

- a best ... c poor

TEMPLATE

may be overlaid on either print or drawing

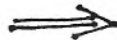

[overhead] ↓ view 7c



view 7

PHOTO CALLS

1. Polaroid print camera should be available in field bag. Archaeologist takes photos, pastes them up in v-file, assigns v#, writes labels and comments on print.
2. Archaeologist calls photographer, discusses print and gives him v#
3. Photographer takes sets of BCD pictures (b/w, color, polaroid slides), and fills out photo log
4. If photos are taken with field camera, archaeologist fills out photo log in Field Book.
5. Archaeologist writes photographer's numbers (e.g. c0325) in v-page for each view.
6. Data from v file (except photo itself) are entered in archaeologist's journal.

F-1-F.05a

F1. FEATURE LOG

MZ8 (1993) Volume A1 f-log, page 3

Date Itls // //	f	k	df	comments
A609	55	k/20	wl	SE center
93	56	k/20	fr	around f51
	57	k/20	stones	W center
	58	k/21	fi	soft, SE portion of locus
	59	k/21	fi	hard, NE " "

F-2-K.05a

F2. LOCUS LOG

MZ8 (1993) Volume A1 k-log, page 1

Date Itls /// ///	k	relay	cm/dir	cm/dir	description
A614	121	r 201	400 N	400 E	square
93	122	r 361	400 N	400 E	"
	123	r 365	400 N	100 E	sector, extension of k/22

F-3-A.06N

F3. AGGREGATE LOG

MZ9 (1996) Volume A8 a-log, page 1

Date Itls // //	a	k	df	>a (elements within aggregate)	ds
G702	1	k17	bee	i4	dirt inside jar
fab	2	k67	bee	f32, i5, i6	
G718	3	k	gully		EW in the North
gb	4	k	gully		NE-SW
	5	k	gully		EW in the South
	6	k68	Courtyard	k68, 69, 18, 19	
	7	k		f4, 17, 18, 6	
	8	k		i3, 7, 5, 18, 21	

F-4-1.G6N

F4. ITEM LOG

MZ9 (1996) Volume A8 i-log, page 1

Date Intls	i	f	k	q	df	ht	lg	w1	w2	wm	sh	co	notes
G702	1	f	1	k	168	q	3	bo	5	12.5	clay		
RAM	2	f	1	k	168	q	10	fg	3	4	clay		ik bird
	\	f		k		q							pr complete
	3	f	3	k	218	q	8	bl	10	1.8	flint		pr whole
	4	f	5	k	168	q	16	go	9	4.5	clay		pr broken longit.
	\	f		k		q							de painted
G703	5	f	5	k	168	q	17	t'	1.7	3	6	clay	5 lines

F-5-Q.G6N

F5. Q LOG

MZ9 (1996) Volume A7 q-log, page 1

Date Intls	q	df (cmpnts)	f	k	HORIZ.DEF. (k or triangul.)			VERT.DEF.		comments
					corner relay	cms ENWS	cms ENWS	start elev.	cms down	
G702	13	bpi	f 16	k 67	entire	locus				
fx	14	bps	f 16	k 67	3/3	100N	200E	9710	20	Diadin
	15	bp	f 17	k 167	entire	locus		9710	15	Ahmad
703	16	p	f 17	k 167	entire	locus		9710	30	Ahmad
	17	pbi	f 16	k 67	3/3	100N	200N	9710	40	Diadin

F-5-Q1.G6N

F5'. NOTES ON Q ITEMS

MZ9 (1996) Volume A7 q-log, page 1

(Refer to Q-lot on facing page)

Date Intls	q-, q.	df	ht	lg	w1	w2	wm	sh	co	notes
G702	13.1	fg	31	4.5	clay					if animal, pr half
fx	.2	fg	2.1	1.8	clay					if animal, pr head only
	14-s1	carbon								
	17.1	bead	.8	1.7	bone?	circul.	white			

F-6-R.D5Q

F6. RELAY LOG

MZ8 (1993) Volume 85 r-log, page 7

NOTE. Standing on 01 and looking at 02, relay must be to your right.

Date	Intls	cl	df	r	rf	rl	t	o1	t1	o2	t2	oe	te
///	constit.	Label	/def	relay	relay def.	relay location	taped	orig of 1	tie1	orig of 2	tie2	orig. elev.	tie elev.
							k	nc		ec		el	
							known	N coord.		E coord.		elev.	
3621	f82	well	179	see s9	NW corner	t	554	135	553	449	9925	103	
93			180	"	SW corner			225		304	"	"	
	KC	locus	181		SW corner		"	117	"	439	"	103	
			182		SE corner		549	494	554	489	9920	52	
			183		NE corner		553	503	551	90	9915	42	
			184		presumed corner temple well		554	515	559	469	9952	70	

F-7-V.G6N

F7. VIEW LOG

MZ9 (1996) Volume A1 v-log, page 1

Date	Intls	v	vr	vo	vf / vi / vq / vk	notes
///	///				(plus pertinent numbers)	vm
A601	v7	m	n	vf 49, 53, 42, 61, 28, 35		
93				12 vi 10, 11 vq 126		
				vk 114		
	v7a	m	s	"		Good duplicate
	v7b	e	s	vf 28		
	v7c	c	e	vi 10 vf 42		
	v8	m	n	vf 28, 31, 5		
	v9	m	e	vf 18 vk 121		

F-8-PHOT.D5Q

F8. PHOTO LOG

MZ8 (1993) Volume 18, page 13

Date Intls	B	C	D	E	F/S	LABEL	SETTING	RANGE	DESCRIPTION
	exposure	exposure	exposure	exposure	exposure	incid., view, item	n,e,s,w ne,se,... ov,on... √, st	c,t,m,w fc,fm,fw	including related labels
	[carry over roll label & number here]								
A621 dq	10	12	6						
	3-5	21-24	10			A/v3	n	m	k121
	6-8					"	n	c	"
	9-15	25-27	11			A1.18	e	t	pin in situ
	16-18					"	e	t	"

F-9-S.D5Q

F9. STRATA LOG

MZ8 (1993) Volume AK s-log, page 1

Date Itls	s	f	ds
///			
c.g.	B6	1,3,8,2	abandonment
	B6a	4?	erosion
	B6-9	5	
	B6	1, 3, 8, 2	abandonment
	B6a	4?	erosion
	B6-9	5	

F10-SPCF.D68

F10. SPECIFIC LABEL LOG

MZ8 (1993) Volume BA Specific Label WA, page 1

Date Itls	seq#	gen-lbl	description
///			
C628 gb	1	B1f31	Phase 1, main W wall
	2	B1f10 + f121	" " N wall
	3	B1f58 + B5f3	" " E wall
	4	B4f38	" " S wall

F11-FILE.F7J

F11. FILE LOG

MZ9 (1996) Volume 9 A, page 3

.fl (f label)	.ed	.ei	proof	.fd (file definition)	.fn (file notes)
<u>C630RAH</u>	<u>C701</u>	<u>RAH</u>	<input checked="" type="checkbox"/>	<u>diary</u>	<u>C628 - C630</u>
<u>C630FAB</u>	<u>C701</u>	<u>FAB</u>	<input checked="" type="checkbox"/>	<u>diary and logs</u>	<u>C627 - C630</u>
<u>C630GB-1</u>	<u>C701</u>	<u>GB</u>	<input checked="" type="checkbox"/>	<u>lists</u>	<u>storage boxes</u>
<u>C630GB-2</u>	<u>C701</u>	<u>GB</u>	<input checked="" type="checkbox"/>	<u>lists</u>	<u>drawings</u>

F11-FILE.F7J

F11. FILE LOG

MZ9 (1996) Volume 9 RAH, page 1

.fl (f label)	.ed	.ei	proof	.fd (file definition)	.fn (file notes)
<u>C628RAH</u>	<u>C628</u>	<u>RAH</u>	<input checked="" type="checkbox"/>	<u>figurines</u>	<u>all from A1</u>
<u>C629RAH1</u>	<u>C629</u>	<u>RAH</u>	<input checked="" type="checkbox"/>	<u>figurines</u>	<u>miscellaneous (Z1, BH, BA)</u>
<u>C629RAH2</u>	<u>C629</u>	<u>RAH</u>	<input checked="" type="checkbox"/>	<u>figurines</u>	<u>humans A1</u>
<u>C630RAH</u>	<u>C701</u>	<u>RAH</u>	<input checked="" type="checkbox"/>	<u>diary A1</u>	<u>C628 - C630</u>

F12-FILM.D69

MZ8 (1993)

Volume VA8, Film label (B,C,D,...) B, page 1



F12. FILM LOG

Film Type:	Roll #'s:	Quantity:	Date:
<u>100</u>	<u>1-30</u>	<u>30</u>	<u>C578</u>
_____	_____	_____	_____
_____	_____	_____	_____
_____	_____	_____	_____

Roll #	Date out	Initials	Camera	Date back	Dt bagged	Comments
<u>1</u>	<u>C603</u>	<u>gb</u>	<u>gb</u>	_____	_____	<u>general shots setting up house</u>
<u>2</u>	<u>C612</u>	<u>gb</u>	<u>gb</u>	_____	_____	<u>" ; early arrivals</u>
<u>3</u>	<u>C615</u>	<u>slh</u>	<u>field</u>	_____	_____	<u>surveying in outer city</u>

Label and sketch, init., date

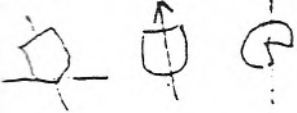
Examples

in			or			ro	
degrees from left plane	highest point of axis	looking at	cardnl point	end of long. axis facing cardnl point	clock positn	outside marker for latit. axis = v l	
Bl. 36 93 85.530 	70 rim	NE	NNW	rim	6	shallow break	
Bl. 37 93 85.603 	∅ (flange)	-	N	flange		(bent point down)	
Bl. 57 93 85.604 	120 center of rim	S	W	rim	1	flat break on rim	

S2. SOIL RECORD

Date _____ Intls _____ Comments _____

Color (Munsell) dry _____ wet _____

Texture Matrix

- present
- partly present
- absent

- grains detectable by hand & eye
- leaves color on fingers
- surface can be made to shine
- when moist coheres into pellets
- if dry, pellets break up & fall apart
- pellets dry out hard
- pellets can be molded into shapes
- silty feel apparent
- silty feel dominant
- when dry rubs off as loose fine powder
- when dry, blows away easily

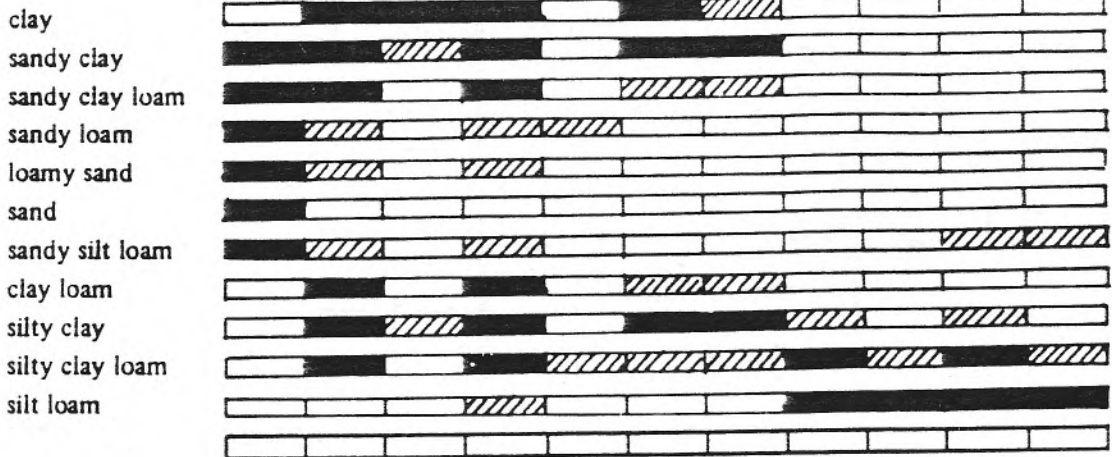

10

Structure



For individual peds:

crumb

granular

blocky

prismatic

columnar

platy

- fine
- medium
- coarse

- < 2mm
- 2-5mm
- > 5mm

- < 2mm
- 2-5mm
- > 5mm

- < 1cm
- 1-2cm
- > 2cm

- < 2cm
- 2-5cm
- > 5cm

- < 2cm
- 2-5cm
- > 5cm

- < 2mm (thin)
- 2-5mm
- > 5mm (thick)

For cluster of peds, when peds cannot be identified:

- massive: holds together as a coherent mass
- single grain: is incoherent and disintegrates into separate particles when disturbed

Estimated dominant, inorganic particle size (use Phi scale): _____

Structure of sedimentary unit: _____

Consistency

- dry: hard (difficult to crush) soft (easy to crush)
- wet: sticky (sticks to fingers if pressed) plastic (can be rolled into "worms")

Boundaries





- merging/sharp
- smooth/wavy/irregular
- upper
- lower

U1. UTILITIES: SYMBOLS AND ABBREVIATIONS

DATE FORMULAS

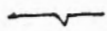
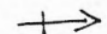
yr	0 1 2 3 4 5 6 7 8 9 A B C ... since 80	e.g.	compressed	extended	normal
mo	1 2 3 4 5 6 7 8 9 x y z		4x1	4x01	October 1, 1984
dy	1 2 3 4 5 6 7 8 9 a a b c d e f g h i j k k l m n o p q r s t u u v		Azs	Az28	December 28, 1990
			C4t	C429	April 29, 1992
			C52	C502	May 2, 1992

GRAPHIC SYMBOLS

-  Excavation boundary (open side refers to area more excavated)
-  North
-  Pointer on drawing or photo template
-  Pointer for direction of view on template
-  Pointer for overhead view on template

CALLIGRAPHY

g g q q b b 6 6 7,77 wet 1 1

FORMAT FOR CODES

Do not leave spaces within label!
Book prefix may be omitted within book corresponding to same prefix.

A1f1	A1q89	A1v18	AK^w3	VC6-0131	Az28
A1a3	A1q89-p	A1r199	AK^r3	VB6a0202	Azs
A1.37 (= A1i37)	A1q89.1 (= A1q89i1)	Y1m578	C1^bk1	VE7-3612	C52

FORMAT FOR TAGS

The following four (+one) points of information must be given, though only the first one is obligatory:

<i>Generic label</i>	<i>Stratigraphy</i>	<i>Date</i>	<i>Initials</i>	<i>Def. (for objects)</i>	
A1.89	f16,k118	C624	gb	figurine	<i>sample entries for item tag</i>
A1q234-p	f16,k118	C624	gb	(jar)	<i>sample entries for lot tag</i>

<i>C624</i> <hr style="width: 80%; margin: 0 auto;"/> <i>rah</i>	<i>A1.89</i> <hr style="width: 80%; margin: 0 auto;"/> <i>f16, k118</i>	<i>A1.89</i>
---	--	--------------

sample tag

COLORS FOR TAGS

Different colors are used for items and various lots. Since the choice is dependent on availability, colors will be posted in the registration room.

LABEL FOR DRAWINGS

Intls _____ Date _____ N. _____

Chkd _____ ExcvsSeason MZ _____ SpfcLbl _____

co _____ c# _____ wm _____ f _____

ht _____ w1 _____ w3 _____ sh _____ **Scale** _____

Measurmnts in cms - Section on right - 5cms on vert.axis

Entries in bold face are obligatory.

N. refers to generic label, which must always be given in full, with complete book prefix, e.g. A1i3.

Codes in lower case are from Main Roster.

U2. UTILITIES: STAFF AND CALENDAR

		A7	A6	A8	TB	TE	TF	TG	TM	TO	TP	V9	Y1	YG	ZC	ZH	ZS
gb	Giorgio Buccellati	x	x	x	x	x	x					x	x	x	x	x	x
mkb	Marilyn Kelly-Buccellati							x	x	x	x						
fxx	Fan-Xi Xu	1						(x)									
jlw	James L. Walker	2														x	x
cln	Carol L. Noyes	x					x	x									
lka	Lara K. Aho	x								x							
af	Alice Frigerio	(x)									x						
rk	Raju Kunjummen		1			(x)											
jo	Jamal Omar		2			x											
rs	Ralph Sariago		x		x		x		x								x
jm	Jennie Myers		x							x							
rah	Rick Hauser			1						(x)							
fab	Federico A. Buccellati			2										x	x		
cew	Christopher E. Woods			x						x							
cw	Claudia Wettstein			x						x							
aag	Anwar Abd el-Ghafour											x					
sag	Samer Abde el-Ghafour											x					
hc	Helene Cooper										x						
lm	Lucio Milano					x											
pp	Pietro Pozzi									x							
bwp	Barabra W. Pritzkat												x				

96	<u>Su</u>	<u>Mo</u>	<u>Tu</u>	<u>We</u>	<u>Th</u>	<u>Fr</u>	<u>Sa</u>
June	23	24	25	26	27	28	29
	30	1	2	3	4	5	6
July	7	8	9	10	11	12	13
	14	15	16	17	18	19	20
	21	22	23	24	25	26	27
	28	29	30	31	1	2	3
August	4	5	6	7	8	9	10
	11	12	13	14	15	16	17

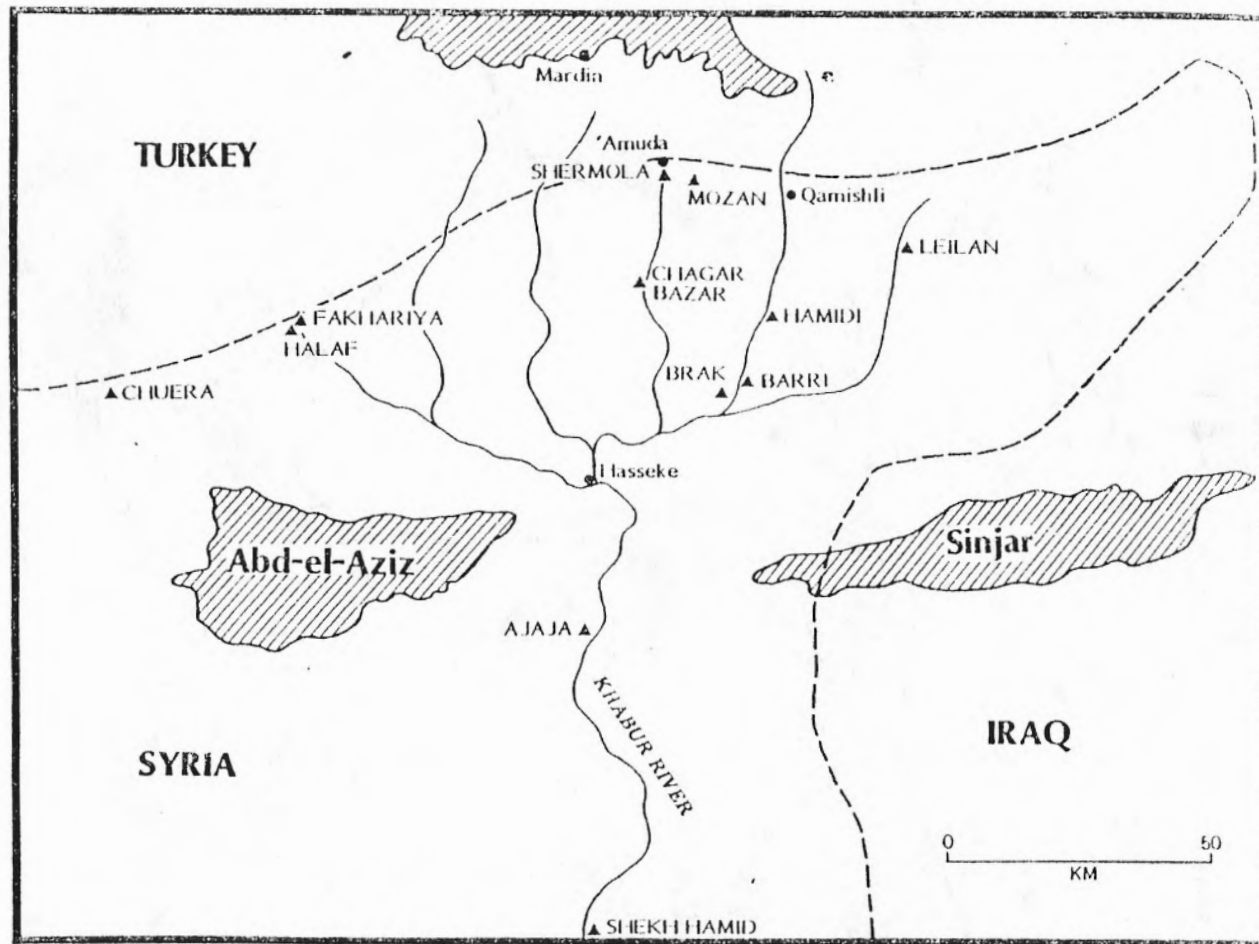

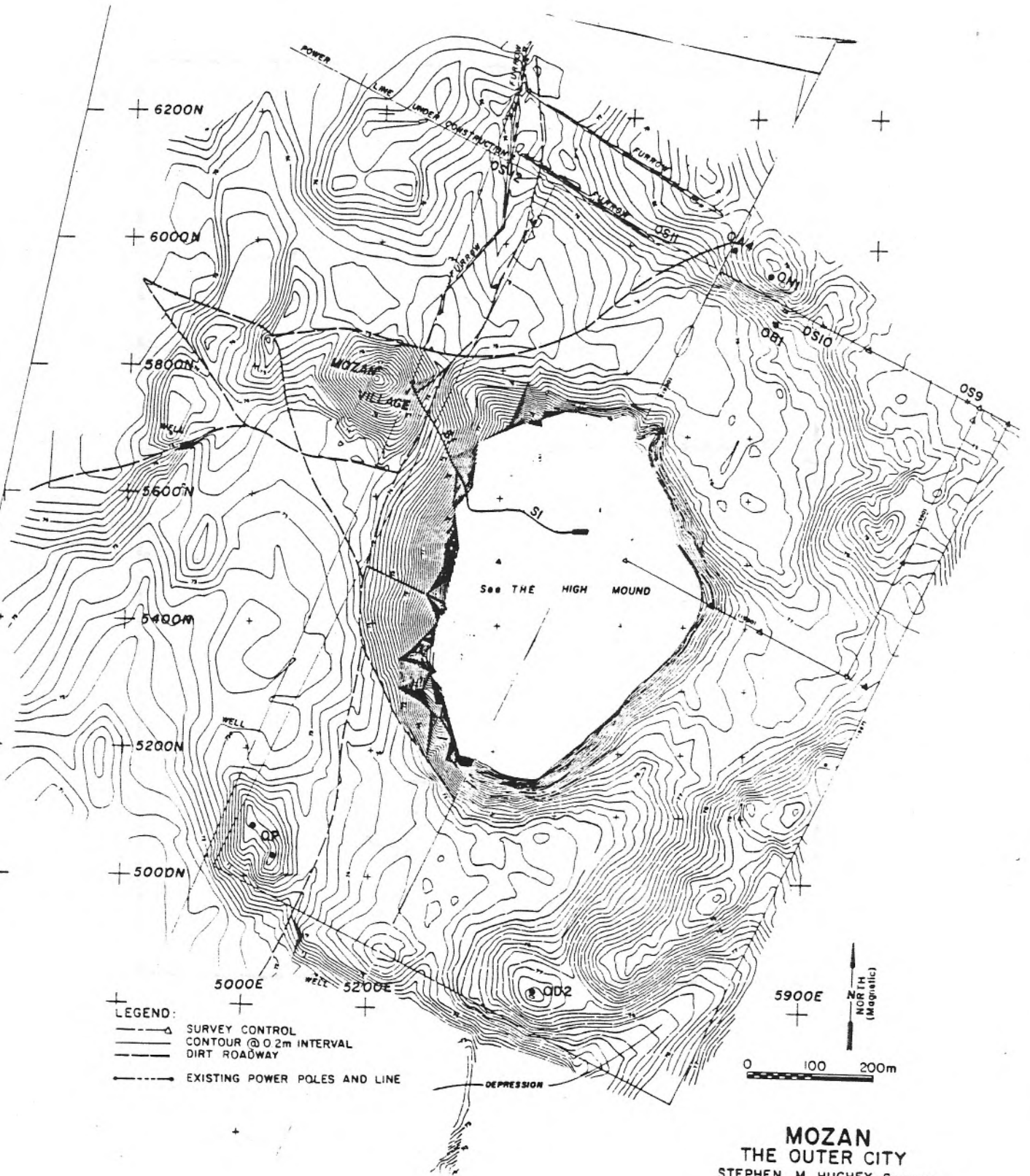

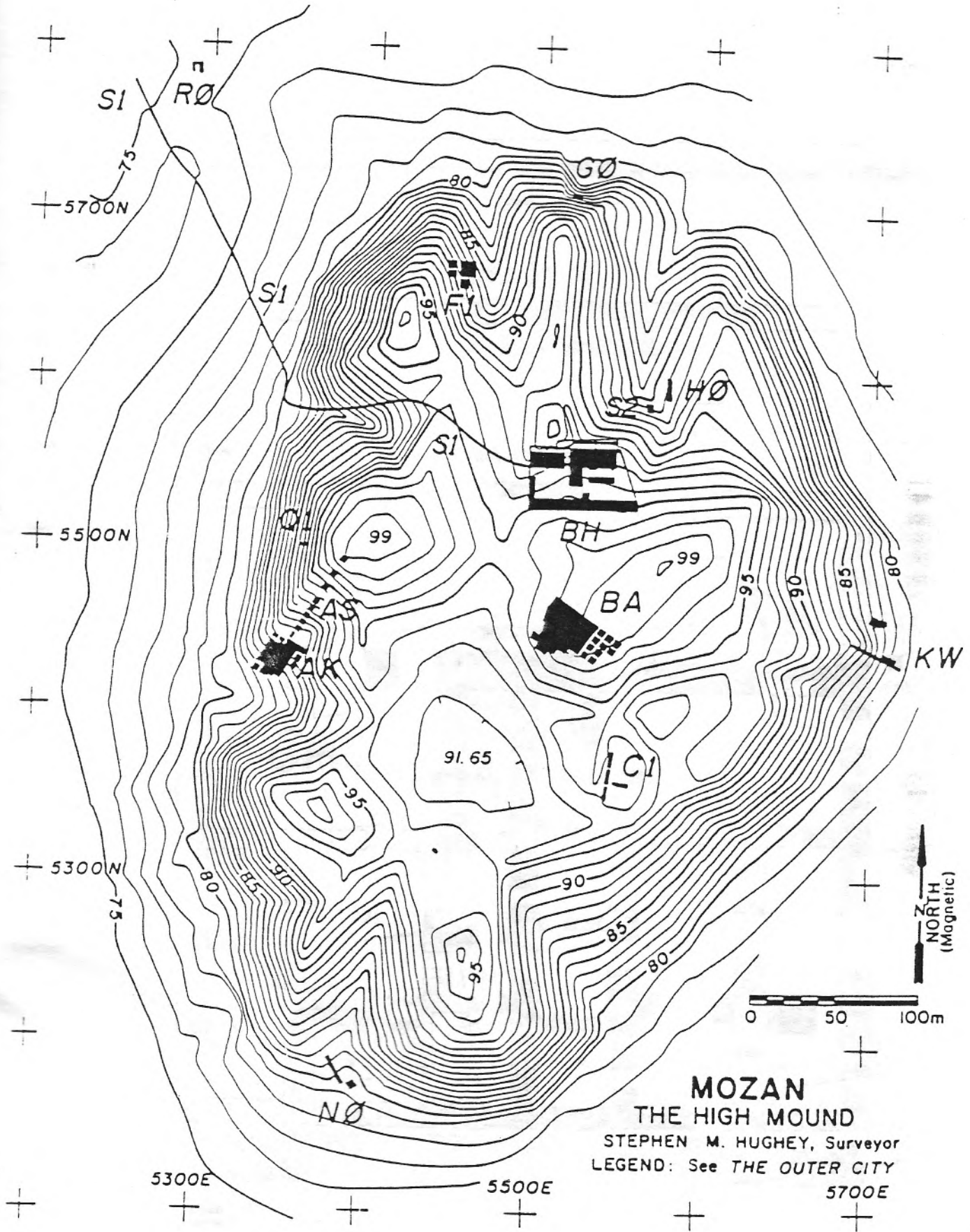

MOZAN
THE HIGH MOUND

STEPHEN M. HUGHEY, Surveyor
LEGEND: See THE OUTER CITY

5700E

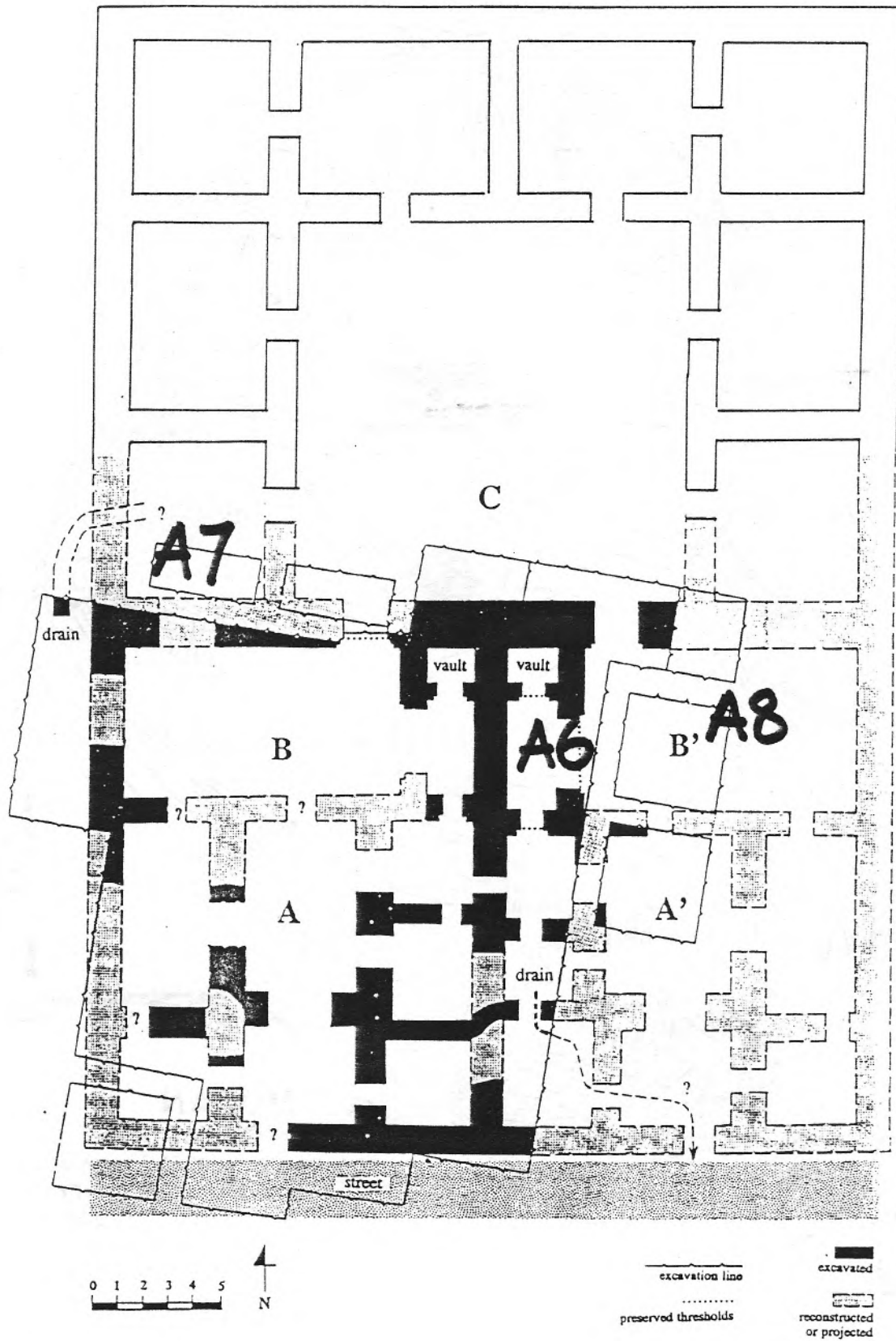

	Original rolling	Mirror image of original rolling
1 a ZA-ni-num ME.DA ne-na 3 ne-na ME.DA ZA-ni-num		
1 b IN-ni-num ME.DA ne-na 3 ne-na ME.DA IN-ni-num		
-2 a sted)		
3 es U SIB) LMU IN-ni-num		
4 es es CTU		

Fig. 3. Seals of the Queen's Household
Scale — 1 cm

	Original rolling	Mirror image of original rolling
k1 Globolet object Esdan a [U]r-keš' KI en-da-an [Tup-ki-š] P - Tup-ki-š P - en-da-an - [U]r-keš' KI		
k2 Reclining lion Esdan b Tup-ki-š [en-da-an] [U]r-keš' KI		
k3 Warrior with helmet Esdan c Tup-ki-š [en-da-an] [U]r-keš' KI		
k4 God with raised foot Esdan d Tup-ki-š [en-da-an] [U]r-keš' KI		
k5 No scene preserved Esdan e [Tup-ki-š] [en-da-an] [U]r-keš' KI		
k6 No scene preserved Esdan f ? [Tup-ki-š] P [en-da-an] [U]r-keš' KI		

Fig. 5. The King's Seals
Scale — 1 cm

	Original rolling	Mirror image of original rolling
q1 ending figures IN ZAGIN-ni-num NIN		
q2 oyal concerts AM Tup-ki-š GINZA-ni-num DAM Tup-ki-š		
q3 our AM B GINZA-ni-num DAM		
q4 AM a AM b ZAGIN-ni-num DAM		
q5 Lyre b ?		

Fig. 6. The Queen's Seals (q1 - q5)

	Original rolling	Mirror image of original rolling
q6 Lyre and table a DAM c ZAGIN-ni-num DAM		
q7 Lyre and table b DAM d [ZAGIN-ni-num] DAM		
q6-7 Lyre and table DAM (conflated)		
q8 Lyre and table e ? DAM e GINZA-ni-num [Tup-ki-š] DAM		

Fig. 7. The Queen's Seals (q6 - q8)
Scale — 1 cm